

Large Motorized Actuator

LTKD

The LTKD type is a motorized actuator suitable mainly for valve sizes 350A and larger, and uses three-phase 200 V and 400 V power supplies. In addition to on-off control, it can be used for slotting control because of its built-in electric positioner (seitroller). It also supports special specification requirements.



■ Features

- Utilizes dedicated high-torque motor.
- Highly reliable counter-gear-type cam limit switch
- Output shaft dual sleeve system
- Supports wide range of output torques and open-close times by combining motors of differing capacities.

LTKD Specifications								
Type	LTKD-01		LTKD-02			LTKD-05		LTKD-1
Motor capacity (kW)	0.2	0.4	0.4	0.75	1.5	0.75	1.5	1.5
Weight (kg)	54	56	71	74	79	74	120	176
Power source (V)	AC200, AC220, AC400V, AC440 50/60Hz Three phase							
Rating (min)	15 min. (With brake: 30 min.)							
Number of poles	4							
Insulation	Class B (option class F and H)							
Motor protection	None (Please provide thermal relay separately.)							
Space heater	Supplied as standard specification (Rated power: 15W)							
Position limit switch	1 each for fully open and fully closed (contact capacity: AC250V, 5A)							
Torque limit switch	1 each for fully open and fully closed (contact capacity: AC250V, 15A)							
Brake	Optional (Will not be supplied as standard.)							
Conduit connection	G1 at two locations (for control) and G3/4 (for motor)							
Enclosure	JIS C 0920 (IP 55), class 5, dust and water-jet proof type							
Manual operation	Always (round handle and built-in manual return clutch)							
Ambient temperature	- 10 to 50 degrees C							
Coating	Lacquer primer (Munsell N7)							
Options	①Potentiometer 500Ω, 1kΩ ②Intermediate limit switch (no voltage) ③Synchro receiver, transmitter ④Seimitter (R/I converter) ⑤Seitroller (DC4 to 20mA I/O) ⑥Withstand pressure anti-explosion type (d2G4)							

Remark: Open and close time differs depending on motor gear ratio (number of sleeve rotations) and type of secondary reducer.

LTKD Dimensions

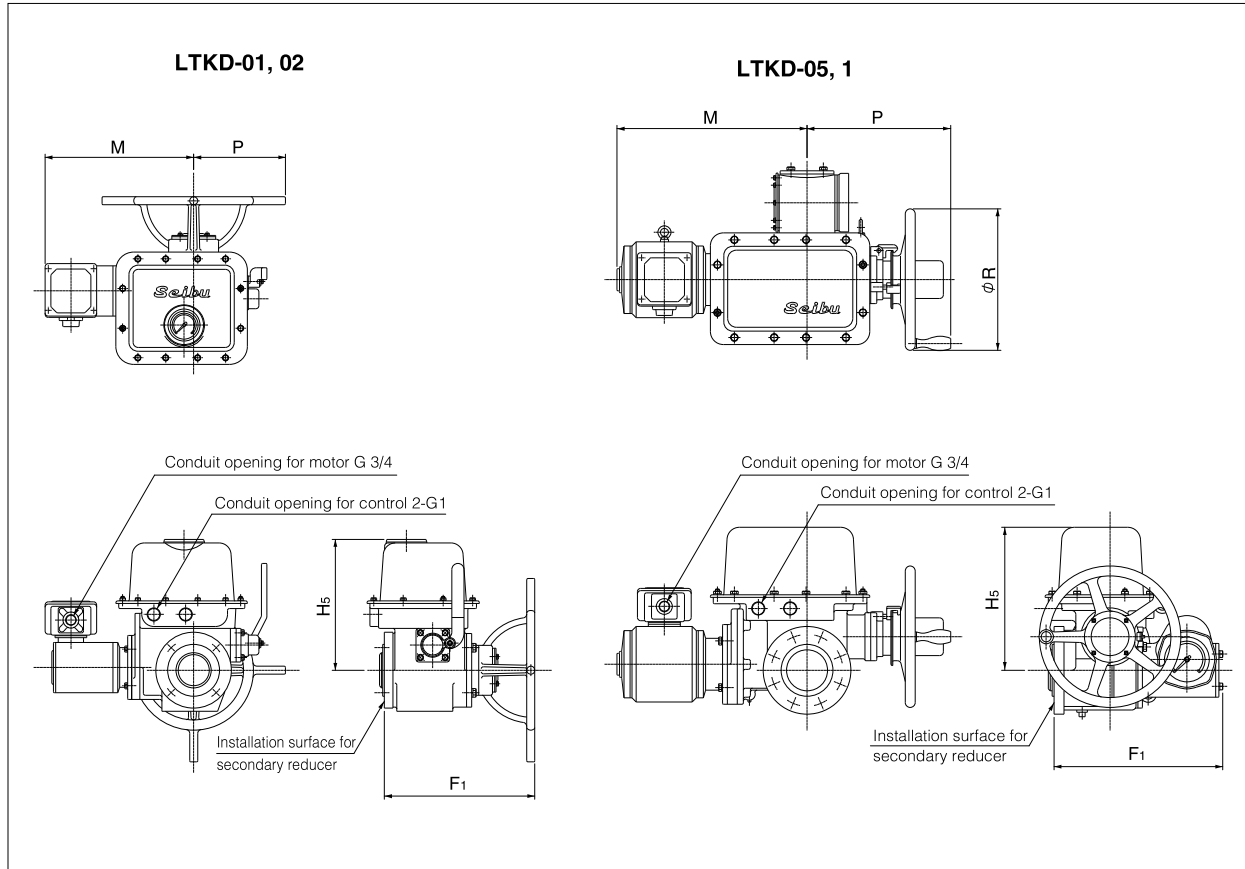

LTKD Dimensions and Weight

Type	Motor capacity	Dimensions (mm)					Approx. Mass (kg)
		M	P	F ₁	H ₅	R	
LTKD-01	0.2kW	364	230	342	293	—	54
	0.4kW	357	230	342	293	—	56
LTKD-02	0.4kW	357	230	378	328	—	71
	0.75kW	375	230	378	328	—	74
LTKD-05	0.75kW	443	360	422	359	160	115
	1.5kW	464	360	422	359	160	120
LTKD-1	1.5kW	503	410	488	399	160	170

Remark: The table above shows dimensions for an actuator with a motor without brake.

Actuator
New ELMY 41
New MICON ELMY II 41
PMK-SRF 4K
SRJ 4J
LTKD 4L
New T-DYNAMO 7E/7F/7G
TGA 3A
TG-S 3K/3U
3C
Diaphragm 6X/6W/6Z/6A/6B
Hydraulic cylinder 3H
Manual Actuators 17/1J/2U/2I/2S/2G/2R

LTKD Motor currents

Type	Impressed voltage (V)	Frequency (Hz)	No brake (Type B and Standard)		With brake (Type B and Option)	
			Rated current (A)	Starting current (A)	Rated current (A)	Starting current (A)
0.2kW	200	50	1.8	7.6	1.8	7.6
	200	60	1.4	6.9	1.4	6.9
	220	50	—	—	—	—
	220	60	1.5	7.6	1.5	7.6
	400	50	0.91	3.9	0.91	3.9
	400	60	0.75	3.6	0.75	3.6
	440	50	—	—	—	—
	440	60	0.78	4.0	0.78	4.0
0.4kW	200	50	2.5	10.2	2.5	10.2
	200	60	2.2	9.6	2.2	9.6
	220	50	—	—	—	—
	220	60	2.2	9.6	2.2	10.6
	400	50	1.2	4.6	1.2	4.6
	400	60	0.99	4.4	0.99	4.4
	440	50	—	—	—	—
	440	60	1.1	4.9	1.1	4.9
0.75kW	200	50	3.9	18.9	3.9	18.9
	200	60	3.5	17.3	3.5	17.3
	220	50	—	—	—	—
	220	60	3.4	19.4	3.4	19.4
	400	50	1.9	9.0	1.9	9.0
	400	60	1.8	8.4	1.8	8.4
	440	50	—	—	—	—
	440	60	1.8	9.5	1.8	9.5
1.5kW	200	50	7.7	38.0	7.7	38.0
	200	60	6.9	35.0	6.9	35.0
	220	50	—	—	—	—
	220	60	6.6	39.5	6.6	39.5
	400	50	3.9	19.0	3.9	19.0
	400	60	3.5	17.5	3.5	17.5
	440	50	—	—	—	—
	440	60	3.3	19.8	3.3	19.8

LTKD Wiring diagram

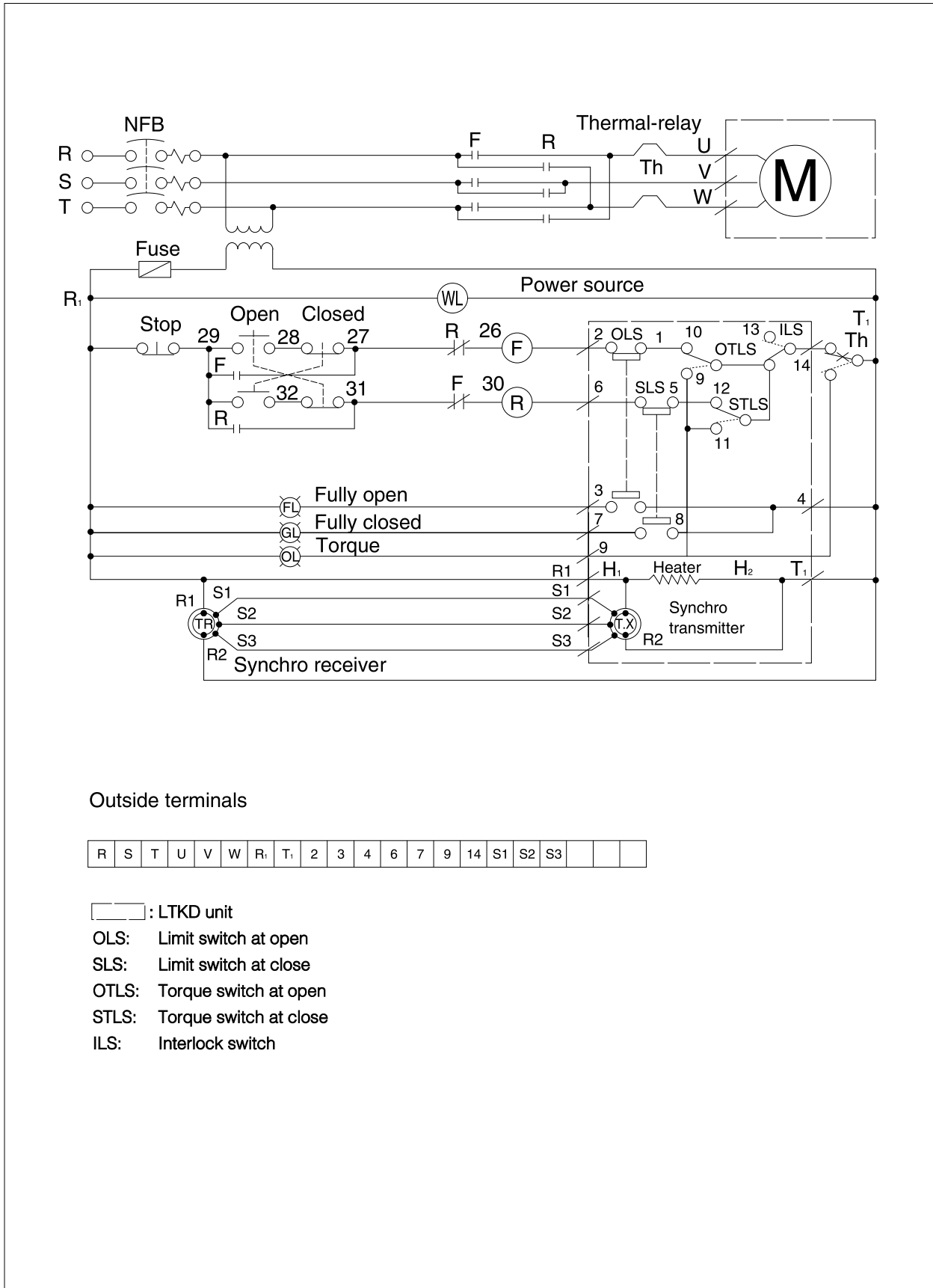

Outside terminals

R	S	T	U	V	W	R ₁	T ₁	2	3	4	6	7	9	14	S1	S2	S3				
---	---	---	---	---	---	----------------	----------------	---	---	---	---	---	---	----	----	----	----	--	--	--	--

□ : LTKD unit

- OLS: Limit switch at open
- SLS: Limit switch at close
- OTLS: Torque switch at open
- STLS: Torque switch at close
- ILS: Interlock switch

Actuator	
New ELMY	41
New MICON ELMY II	41
PMK-SRF	4K
SRJ	4J
LTKD	4L
New T-DYNAMO	7E/7F/7G
TGA	3A
TG-S	3K/3U
3C	
Diaphragm	6X/6W/6Z/6A/6B
Hydraulic cylinder	3H
Manual Actuators	17/1J/2U/2I/2S/2G/2R